

Thank you for purchasing a Silverlynx product

As one of Australia's leading bedroom furniture manufacturers, we have long established partnerships with Australia's most successful retailers.

Customers who buy our products recognise our commitment to quality and customer satisfaction.

Silverlynx is a value's based business. Our commitment to quality, evolving design leadership, customer service and exceeding customer expectations - is unsurpassed in the industry.

Enjoy your Silverlynx product.

BY DESIGN GAS LIFT

Assembly Instructions

Please retain these instructions for future reference



Please read through these assembly instructions carefully to ensure that you can assemble your new purchase without stress. These detailed instructions will guide you on how to prepare and assemble your bedroom suite.

DIFFICULTY

NOVICE One person, no additional equipment	MODERATE Two people, no additional equipment	MODERATE* Two people, additional equipment required	EXPERT Qualified tradesperson recommended
--	--	---	---



WE ADVISE YOU DO NOT USE POWERED DRILLS TO ASSEMBLE ANY BOLTS ON THIS BED

Please note, your bed head & foot may look different to this image, however the following instructions will still apply

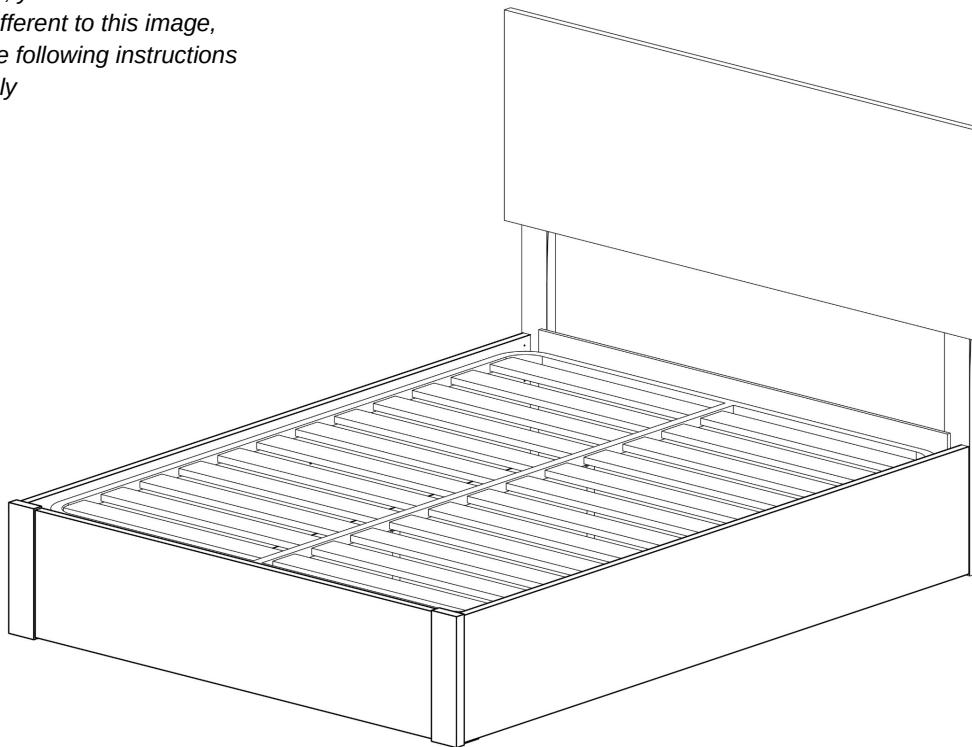

EQUIPMENT PROVIDED

Hardware Pack: containing - 12x (M6) 10mm button head bolts; 4x 15mm phillips head screws; 6x 45mm mushroom head bolts; 6x nuts; 1x allen key

G



x12



x4

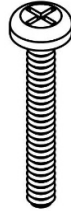

x6



x6

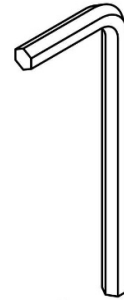

x1

Note: there is additional hardware pre-fitted to your bed components. These instructions will guide you on how to use them to assemble your bed

Bed Components

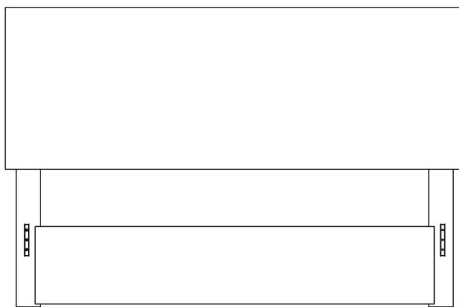

Bedhead**

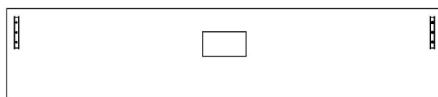

Bed Foot (with GAS LIFT Block)**



Mattress Bar



Fabric Strap

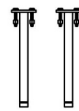

2x Support Legs*
(inc. bolts & nuts)
KING & QUEEN
only

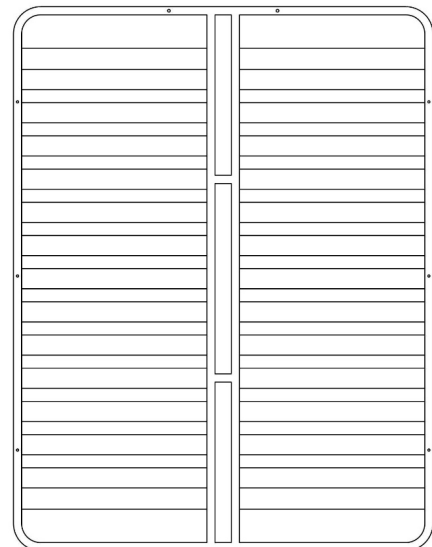

Gas Lift Slats

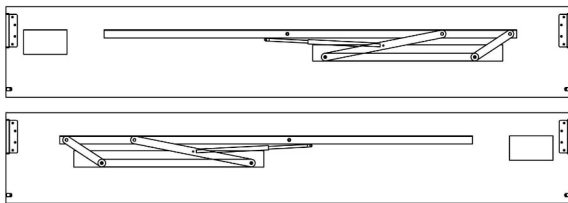

2x Siderails (with attached Gas Lift Struts)

*KING & QUEEN ONLY. Double, King Single, and Single Gas Lift Bases do not have support legs

**Please note, your bed head & foot may look different, however the following instructions will still apply

Not Provided: Phillips head screwdriver, Flat head screwdriver



STEP 1 – Position Bed Head, Foot, and Side Rails approximately where your bed is to be set up. *NOTE* the Gas Lift Struts (which are pre-attached to your Side Rails) are set up closer to the head end as shown. Connect the Side Rails to the Bed Head by hooking the Side Rail brackets onto the Head brackets.

STEP 2 – Screw three button head bolts (M6) into the position shown to connect the Side Rails to the Bed Head and tighten (finger tight only).

*Having trouble? See *Helpful Tips* at the end of this document.*

STEP 3 – Complete the above process on the other Side Rail, then repeat with the Foot Panel.

STEP 4 – Optional angle brackets located near the bottom of each end of your Siderails can be fixed to the Head and Foot, keeping the Siderails parallel. Use the 15mm screws provided to screw through the angle bracket (*you will need a Phillips head screwdriver*).

STEP 5 – Ensure the bed is square and then tighten the button head bolts using the allen key provided. Once snug, tighten only with $\frac{1}{4}$ turn of the Allen Key. **DO NOT USE** cordless drivers or power drills as over-tightening can cause the head and foot end to bow. Your bed should now look like the following diagram.

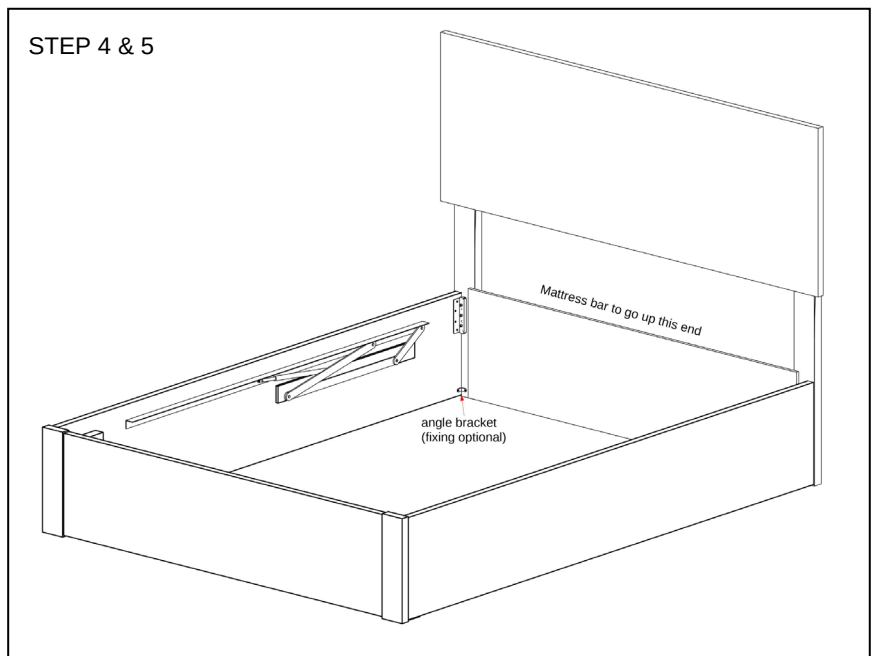
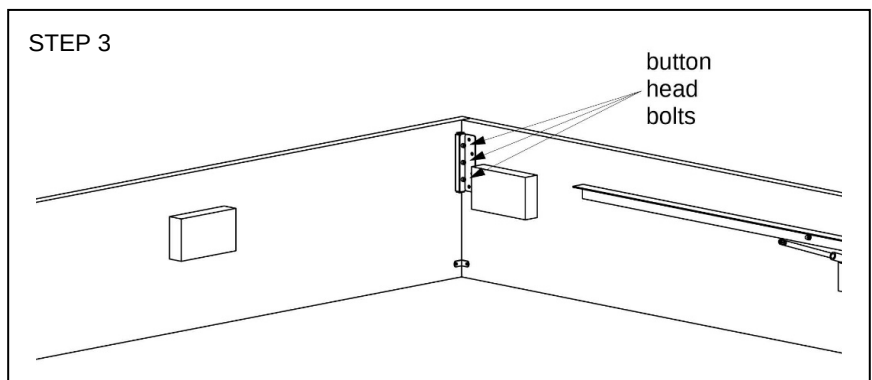
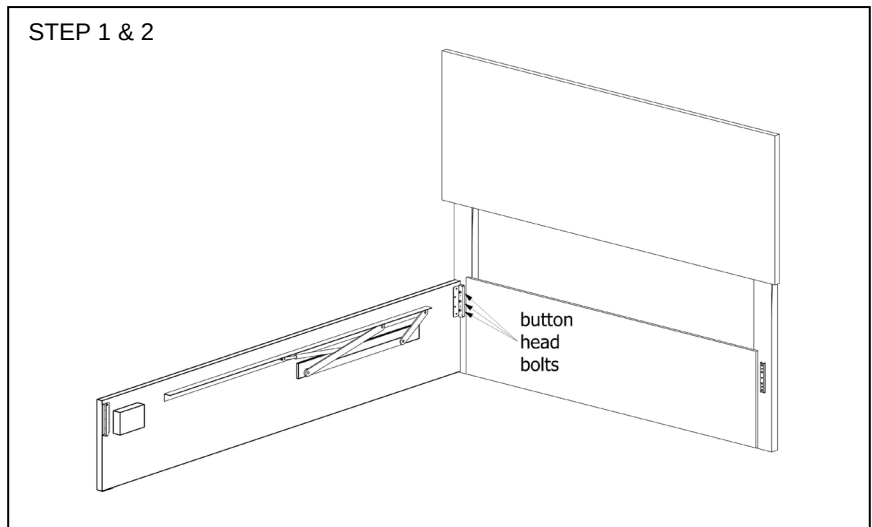

STEP 6 – Setting up the Gas Lift Struts & Slat Frame

The Gas Lift Strut has been pre-fixed to your side rails. To connect them to the slats, first remove the lock nut.

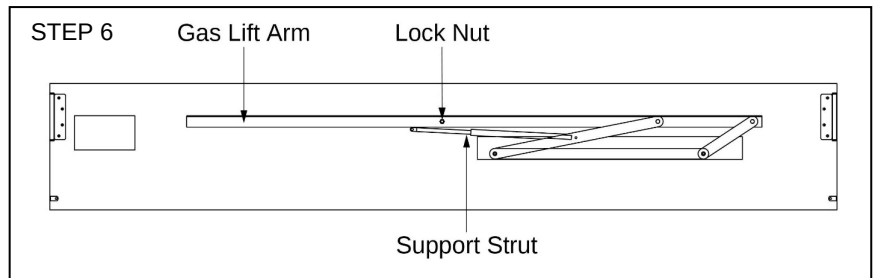

STEP 7 – Lift up the Gas Lift Arm and line up the bolt with the hole in the Support Strut.

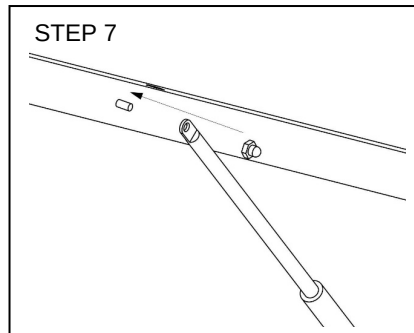

STEP 8 – Place the Support Strut over the bolt and secure using the lock nut.

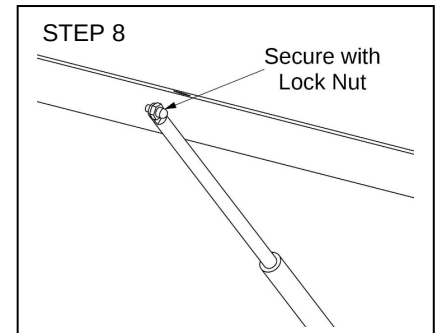

STEP 9 – Repeat Steps 6-8 on the other Side Rail.

STEP 10 – There are two holes at the head end of your Slat Frame where the Mattress Bar will be fixed. Remove the nuts that are pre-fitted pre-fit to your Mattress Bar and secure onto the Slat Frame as shown. This will ensure that your mattress will not slide into the bed head when accessing the gas lift storage.

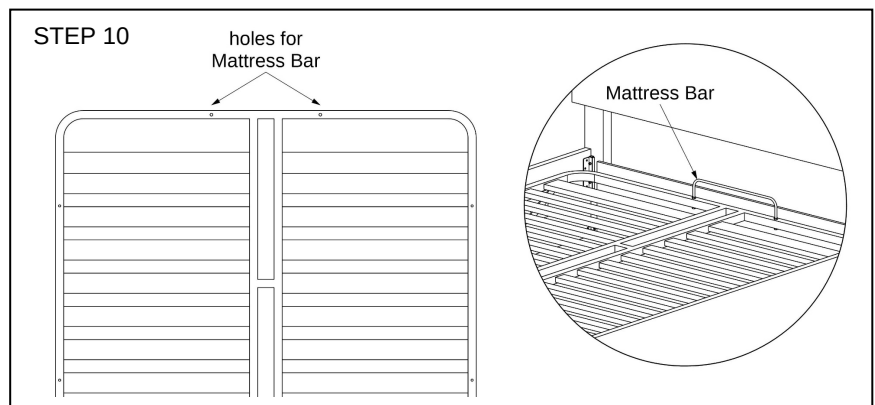

STEP 11 – Place the Slat Frame in position on top of the Gas Lift Struts so that the holes on the Gas Lift Struts line up with the locator holes along the sides of the Slat Frame.

STEP 12 – Use the 6x 45mm mushroom head bolts & 6x nuts provided to secure the Slat Frame onto the Struts. The slots on the Gas Lift Struts allow you to adjust the Slat Frame forward or backwards as needed. Use this adjustment so that **once the slats are 'closed', they rest on the cleat on the Foot End rail – see diagram next page.** (Note, without a mattress placed on top of the Slat Frame, your Gas Lift bed will stay in an 'open' position).

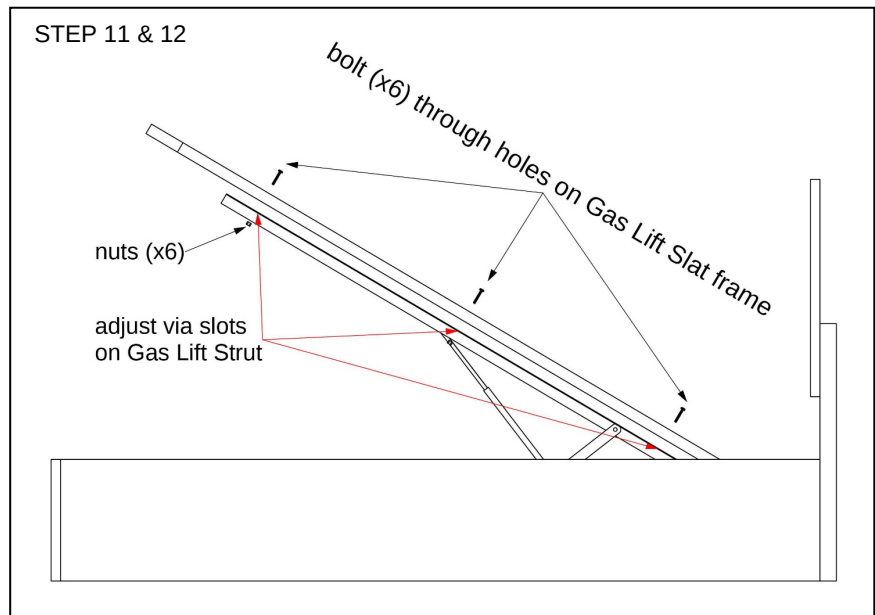

STEP 12
CONTINUED

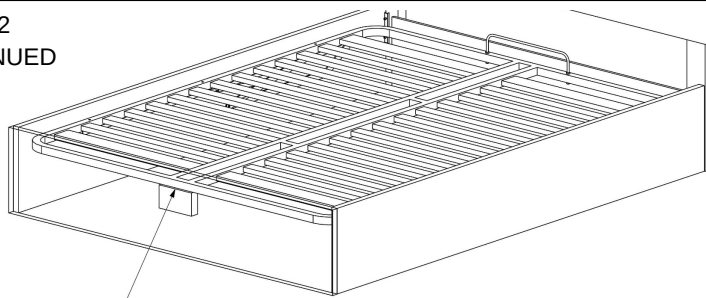

Slat frame **MUST rest on support cleat when closed**. Adjust using slots on Gas Lift Struts (as above)

STEP 13 – (For King & Queen Beds)

Fit Support Legs as shown below by fixing to the centre rail of the Slat Frame in the locations shown. Remove the bolts & nuts that are pre-fit to your Support Legs and secure the Leg to the Slat Frame, ensuring the nut is installed on the underside of the Slat Frame and Leg. Note, this step is only necessary if you have either a King or Queen Bed. *Double, King Single, and Single sizes beds do not require a Support Leg.*

STEP 13 - 14

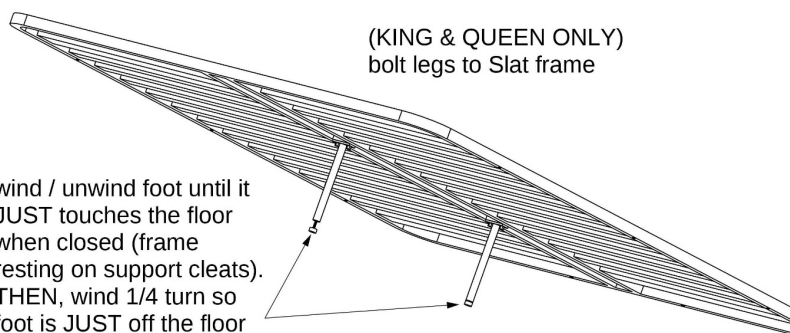

STEP 14 – Fine tune the Support Leg/s by unscrewing the foot so that it sits **JUST above the floor when closed** (frame resting on support cleats). We recommend adjusting the leg to touch the floor when closed, then winding the foot back up by 1/4 turn to adjust.

STEP 15

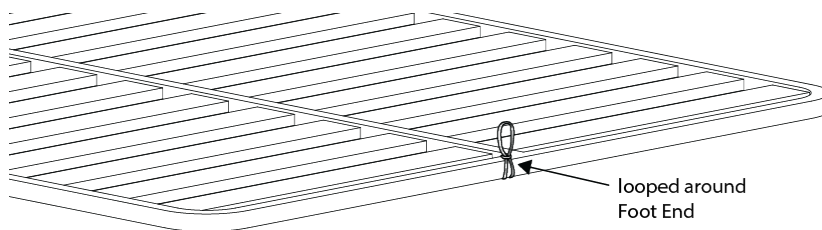

STEP 15 – Loop the Fabric Strap Handle around the foot end of the Slat Frame as shown below. This can now be used as a handle to lift your bed for access to the storage space below

STEP 16 – 'Close' the Slat Frame and place your mattress on top (you may need to lift your mattress onto the 'open' slats to have enough weight to 'close' the slats). Your Gas Lift Bed is now ready to enjoy

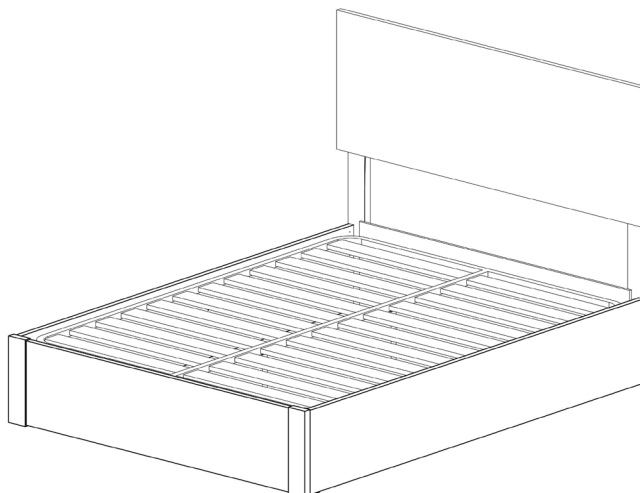

****Helpful Tips****

STEP 2 & 3

The button head bolts that connect the Siderails to the Bed Head & Foot can sometimes be tricky to align. If you are having trouble, try to lift the Siderail slightly while you connect the bolts (it may be easiest to slide something narrow underneath the Siderail to prop it up slightly – *eg. use these instructions folded*). This can help line up the holes in both brackets so that the bolt can connect easily.

GENERAL

Make sure not to tighten bolts before attaching all components and making sure they sit square. Once you are ready, make sure all bolts are snug, then tighten **only** with ¼ turn of the Allen Key. **DO NOT USE** powered drills as over-tightening can cause components to bow.

NOTES

- Button head bolts should be regularly inspected and may need to be retightened periodically
- **Never drag or move assembled furniture as this may cause damage**

CARE & MAINTENANCE

Your Silver Lynx product is crafted with care, properly maintained, it will mature over time developing a rich deep patina enhancing its appearance. To get the best performance from your SilverLynx product, please follow the simple care instructions listed below.

- Do not use silicone based polishes/cleaners at any time.
- Dust surfaces gently with a feather duster then wipe gently with a slightly damp cloth/chamois.
- Do not allow liquids, damp clothes to remain in contact with lacquered surface for extended periods.
- Never place furniture in close proximity to heating outlets.
- Exposure to direct sunlight will cause colour fading to fabrics, leathers and timber finishes.
- Do not allow solvents, abrasives or heated objects to come in contact with the product.
- Do not use cordless drivers or power drills to tighten any bolts, as over-tightening can cause components to bow, and can cause damage to the bolts.

Contact your retailer or our sales office for further information

