

Thank you for purchasing a SilverLynx product

As one of Australia's leading bedroom furniture manufacturers, we have long established partnerships with Australia's most successful retailers.

Customers who buy our products recognise our commitment to quality and customer satisfaction.

SilverLynx is a **values**-based business. Our commitment to quality, evolving design leadership, customer service and exceeding customer expectations - is unsurpassed in the industry.

Enjoy your SilverLynx product.

CALVERTON HEAD ONLY

Assembly Instructions

Please retain these instructions for future reference



Please read through these assembly instructions carefully to ensure that you can assemble your new purchase without stress. These detailed instructions will guide you on how to prepare and assemble your bedroom suite.

DIFFICULTY

NOVICE One person, no additional equipment	MODERATE Two people, no additional equipment	MODERATE* Two people, additional equipment required	EXPERT Qualified tradesperson recommended
--	--	---	---



WE ADVISE YOU DO NOT USE POWERED DRILLS TO ASSEMBLE ANY BOLTS ON THIS BED

Please note, your bed head may look different to this image, however the following instructions will still apply

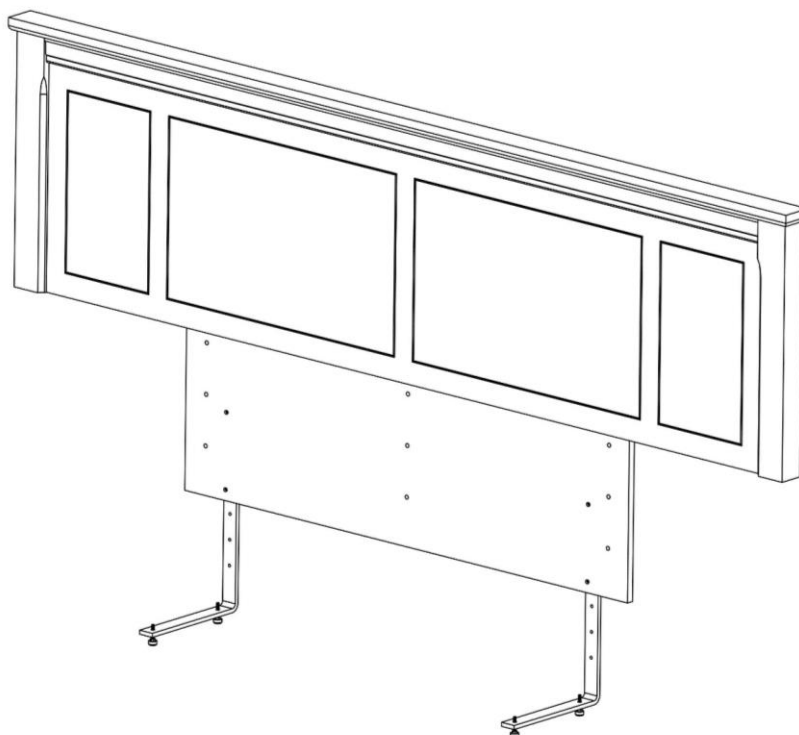

EQUIPMENT PROVIDED

Hardware Pack: containing - 4x (M6) 25mm hex head bolts; 4x (M10) 50mm adjustable feet; 1x allen key



x4

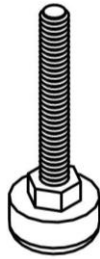

x4

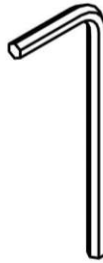

x1

Note: The hardware pack may contain more items than required. Please contact our sales team if you have any questions/concerns.

Bed Frame Parts:

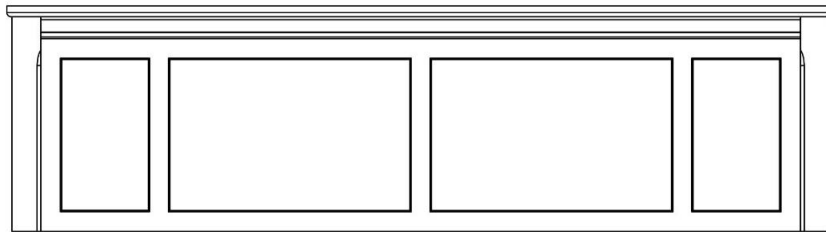

Bedhead

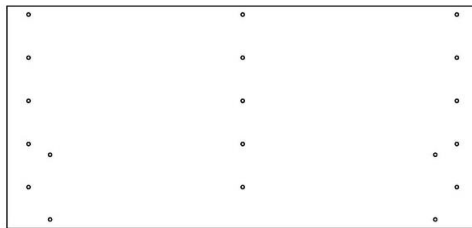

Support Panel

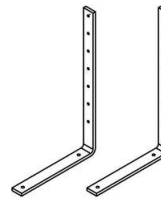

2x 'L' Legs

Please note, your bed head may look different to this image, however the following instructions will still apply

Slat System: N/A

Not Provided: Adjustable Wrench

We recommend laying a blanket on the floor and working with your Bed Head parts on the blanket to protect your Bed Head and floors from being scratched during assembly. The following instructions will guide you to set your Bed Head to the recommended height of 1380mm.

STEP 1 – Carefully place bedhead face down near the position that your bed is to be set up. Remove the 6x 30mm bolts that are pre-fitted to the back of your bedhead. Note – there are rubber stoppers installed in the top back corners of the bedhead as shown. These will prevent the wall & Bed Head from touching.

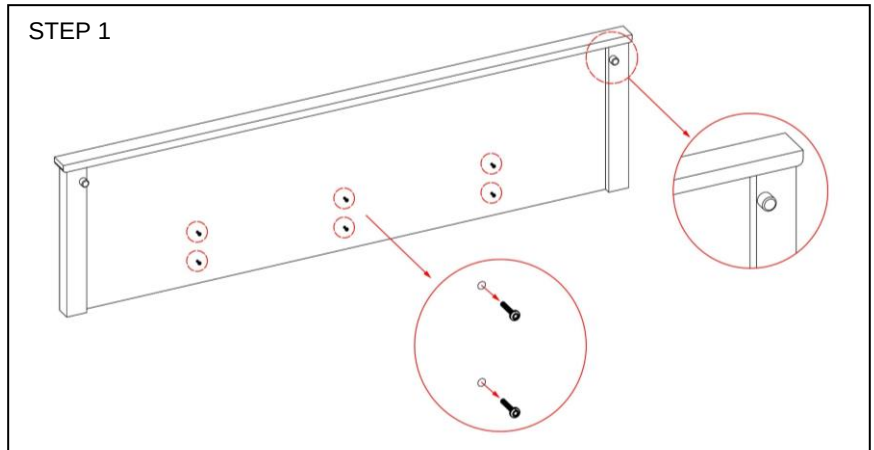

STEP 2 – Identify the top and bottom of the Support Panel by locating the 4x pre-fitted skein nuts toward the bottom of the Panel. Make sure the flange of the skein nut is facing toward you.

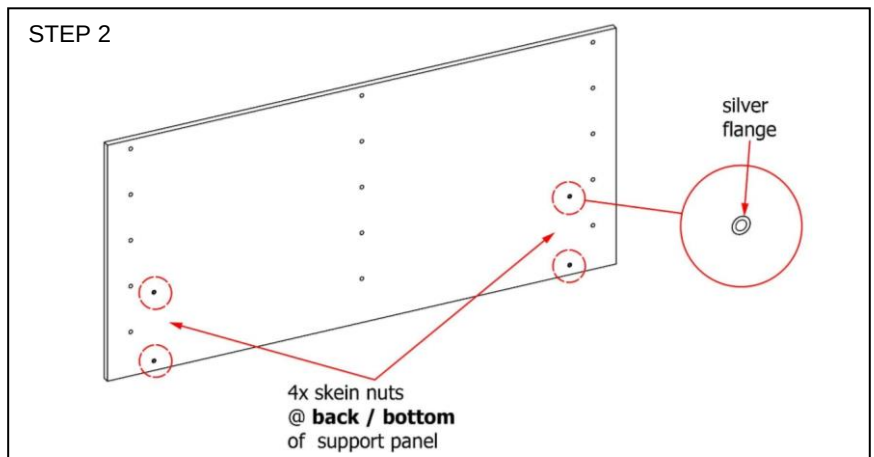

STEP 3 – Position the Support Panel on the back of the Bed Head so that the top two rows of holes line up with the holes in the back of the Bed Head as shown. Using the 6x 30mm bolts removed in step 1, secure Support Panel to the back of Bed Head.

DO NOT overtighten – once snug, tighten with $\frac{1}{4}$ turn of the allen key provided. *DO NOT USE* powered drills as overtightening can cause the bolt threads to strip.

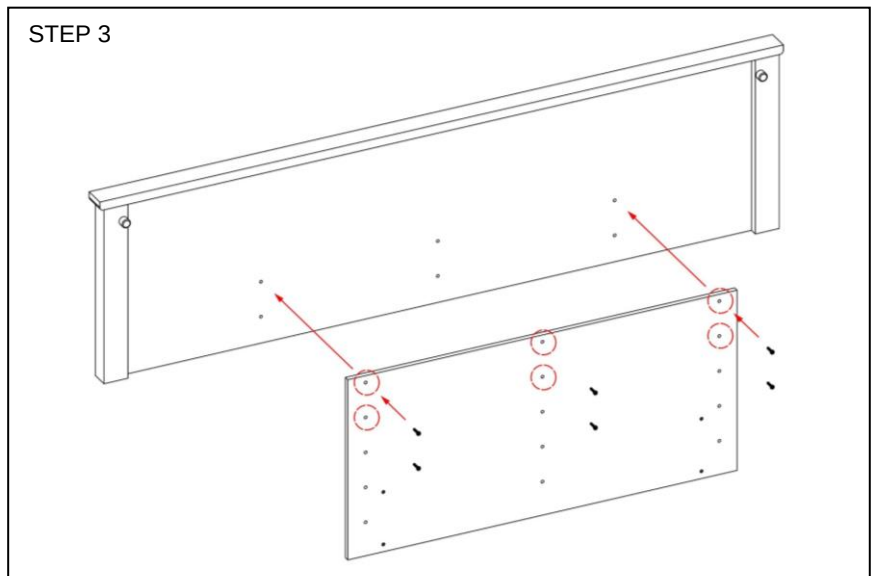

STEP 4 – Prepare Legs.

You have been provided with 4x Adjustable Feet which can now be fitted to the bottom of the L Legs as shown. Install the front foot so that the end of the bolt sits just proud of the L Leg. Install the back foot so the end of the bolt sits approximately 10mm proud of the L Leg. This is to ensure that the Bed Head will lean back slightly and rubber stoppers will rest on the wall, making the Bed Head stable. Legs can be fine tuned after the next step.

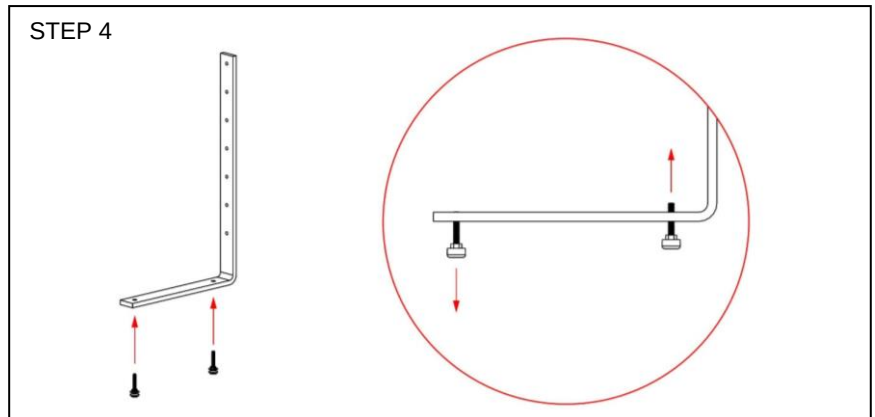

STEP 5 – Using the 4x 25mm bolts provided, install L Legs, lining the 1st & 4th holes from the top of the Leg with the skein nuts on the back of the Support Panel.

DO NOT overtighten – once snug, tighten with ¼ turn of the allen key provided. **DO NOT USE** powered drills as overtightening can cause the bolt threads to strip.

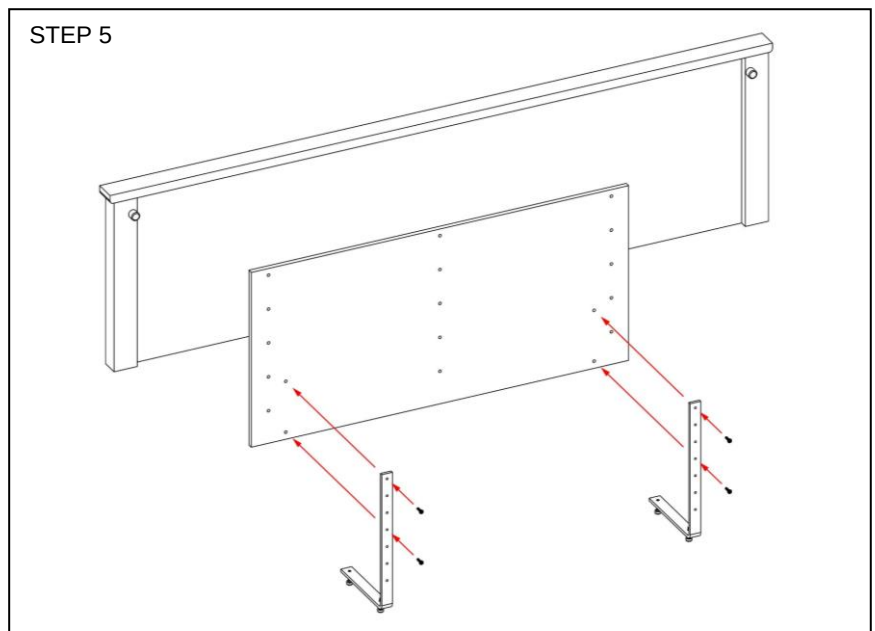

STEP 6 – Carefully lift your Bed Head into position, ensuring it leans slightly against the wall. Using an adjustable wrench, fine tune the feet so that both sit firmly on the floor – keeping the lean in the Bed Head. You may need to fine tune the height to ensure the Bed Head will clear your Calverton Bedside, We recommend a clearance of 710mm, which will give a gap of approximately 15mm above your Bedside (may appear different on heavy carpet).

An ensemble base can now be installed in front of the Bed Head, ready for use.

NOTE: These instructions show the recommended height of 1380mm which will suit the Calverton Bedside and is the maximum height available. Height is adjustable using different hole positions on Support Panel and 'L' Legs to a minimum height of 940mm. Lowering the Extended Bed head is not recommended as it will not suit Calverton Bedside.

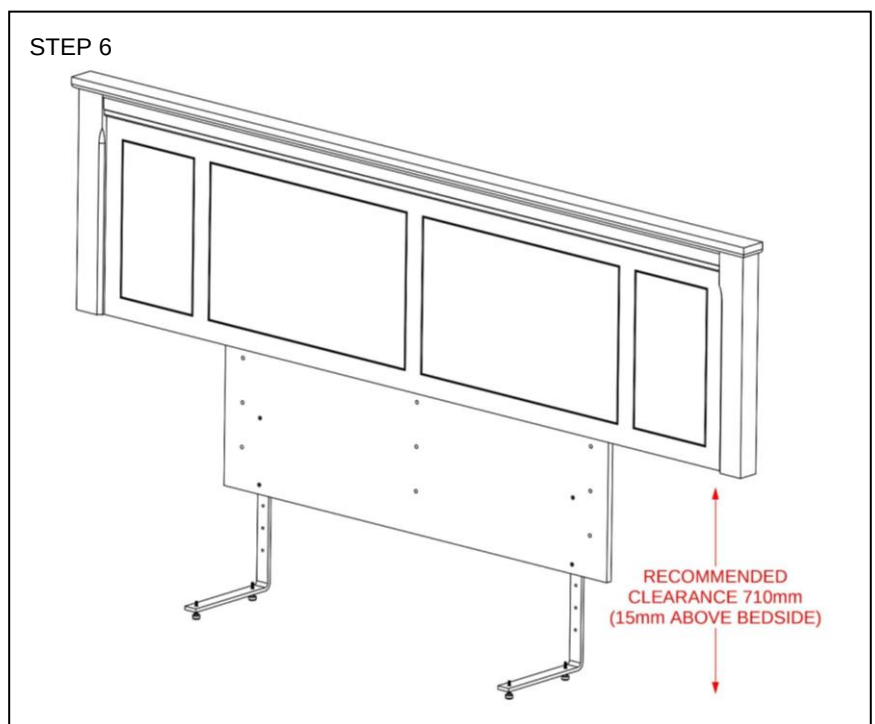

Helpful Tips

GENERAL

Make sure not to tighten bolts before attaching all components and making sure they sit square. Once you are ready, make sure all bolts are snug, then tighten **only** with ¼ turn of the Allen Key. DO NOT USE powered drills as over-tightening can cause components to bow.

Never force bolts if you can feel resistance as this can cause the thread to strip. Try to adjust the hole alignment until your bolt can connect easily by hand.

NOTES

- Bolts should be regularly inspected and may need to be retightened periodically
- **Never drag or move assembled bed as this may damage the bed**

CARE & MAINTENANCE

Your SilverLynx product is crafted with care, properly maintained, it will mature over time developing a rich deep patina enhancing its appearance. To get the best performance from your SilverLynx product, please follow the simple care instructions listed below.

- Do not use silicone based polishes/cleaners at any time.
- Dust surfaces gently with a feather duster then wipe gently with a slightly damp cloth/chamois.
- Do not allow liquids, damp clothes to remain in contact with lacquered surface for extended periods.
- Never place furniture in close proximity to heating outlets.
- Exposure to direct sunlight will cause colour fading to fabrics, leathers and timber finishes.
- Do not allow solvents, abrasives or heated objects to come in contact with the product.
- Do not use cordless drivers or power drills to tighten any bolts, as over-tightening can cause components to bow, and can cause damage to the bolts.

CARE & MAINTENANCE – QUARTZ STONE TOP

To get the best performance from your Quartz Stone Top, please follow the simple care instructions listed below.

- For everyday cleaning, use warm soapy water (a pH neutral/ or a mild liquid detergent) and a damp cloth
- Avoid prolonged rubbing in one spot when cleaning
- Polishing/waxing surface is not recommended due to the non-porous nature of material which will retain its glossy finish
- Quartz stone is a non-porous material with good stain resistance, however we advise you do not allow liquids or wet food to have prolonged contact with the stone top. Wipe up any spills as soon as they occur
- Do not use bleach or cleaning products with high alkaline/pH levels on or near your Quartz stone product.
- Quartz stone is resistant to *moderate* temperature, however we advise you do not place hot cookware directly onto the stone as this can cause damage/discoloration. Use a trivet or other protective object for hot items
- For indoor use only
- Exposure to direct sunlight will cause discolouration

Contact your retailer or our sales office for further information

