

Gas Lift Bed

Assembly Instructions

Please retain these instructions for future reference

Thank you for purchasing a Silverlynx product

As one of Australia's leading bedroom furniture manufacturers, we have long established partnerships with Australia's most successful retailers.

Customers who buy our products recognise our commitment to quality and customer satisfaction.

Silverlynx is a value's based business. Our commitment to quality, evolving design leadership, customer service and exceeding customer expectations - is unsurpassed in the industry.

Enjoy your Silverlynx bed.

Please read through your assembly instructions carefully to ensure that you can assemble your new purchase without stress. You have been provided with detailed instructions on how to prepare and assemble your bedroom suite.

Gas Lift Bed

NOTE – two people are required to assemble this bed

WE ADVISE YOU DO NOT USE POWERED DRILLS TO ASSEMBLE ANY PART OF THIS BED

To assemble your bed you have been supplied with

12x 12mm button head bolts; **4x** 15mm phillips head screws; **6x** mushroom (phillips) head bolts; **6x** nuts; **1x** allen key

2x Side Rails with attached Gas Lift Struts

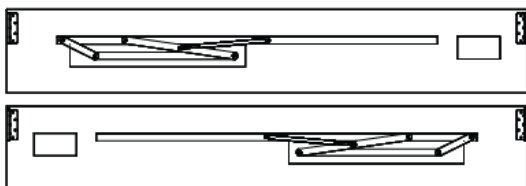

Bed Foot



Bed Head**



Fabric Strap



Support Leg*

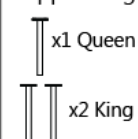

*NO SUPPORT LEG
For Double
King Single
or Single size

Mattress Bar

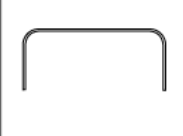

Posture Slats

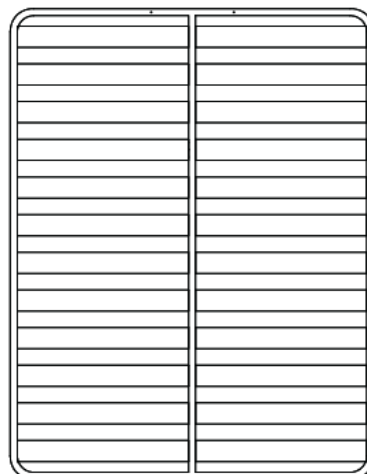

**Pictured is the bed head for our DIVAN RANGE

Please note your bed head may look different, however the following instructions will still apply.

STEP 1 – Attaching the Side Rails to the Bed Head & Foot

Lay out the Bedhead, Foot, and Side Rails roughly in the position your bed is to be set up. Make sure the Gas Lift Struts (pre-attached to side rails) are set up closer to the head panel as shown below. Connect the side rails to the bedhead by hooking the side rail bracket onto the bed head bracket and fix using 3x 65 mm button head bolts (only finger tight). Repeat on the foot end.

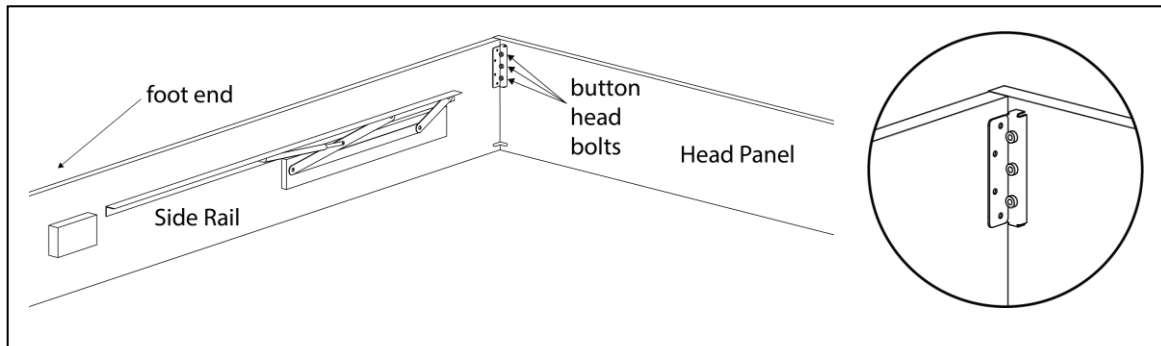

STEP 2 – Optional angle brackets located near the bottom of each end of your side rails can be fixed to keep the side rails parallel with the bedhead and foot. Use the 15mm screws provided to screw through the angle bracket. Once snug, tighten only with 1/4 turn of the Allen Key. **DO NOT** USE cordless drivers or power drills as over-tightening can cause the head and foot end to bow.

STEP 3 – Ensure the bed is square and then tighten the button head bolts using the allen key provided.

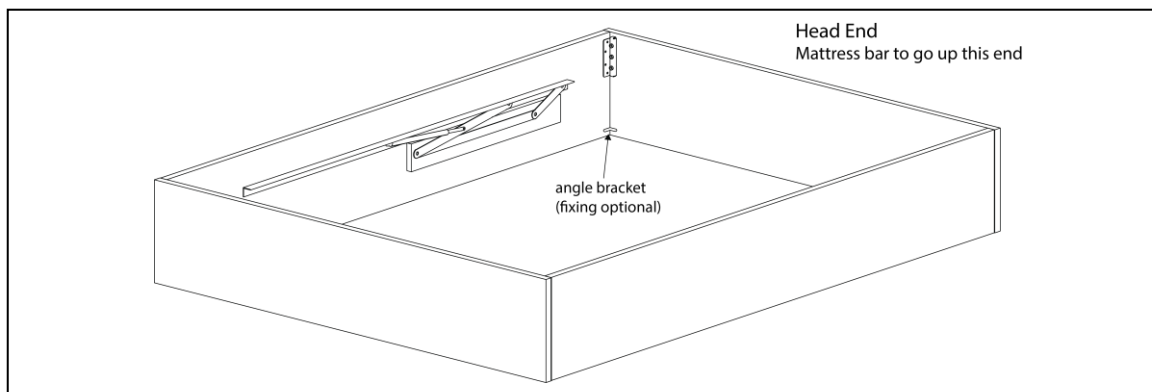

STEP 4 – Setting up the Gas Lift Struts & Posture Slat Frame

The Gas Lift Strut has been pre-fixed to your side rails. To connect them to the posture slats, first remove the lock nut (shown below).

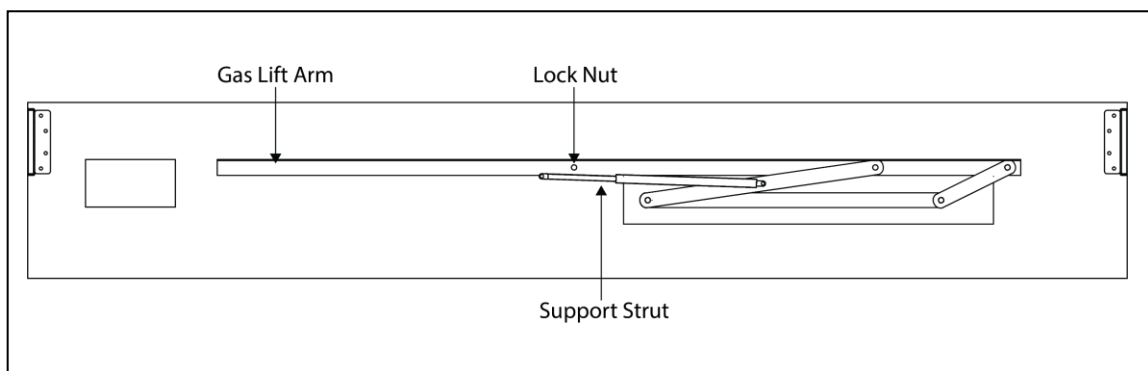

STEP 5 – Lift up the Gas Lift Arm and line up the bolt with the hole in the Support Strut.

STEP 6 – Place the Support Strut over the bolt and secure using the lock nut (Steps 5 & 6 shown below).

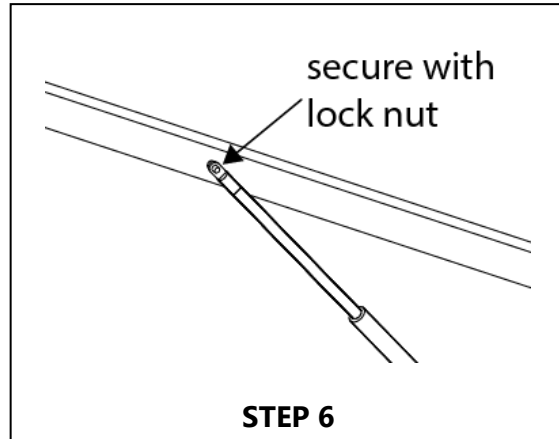
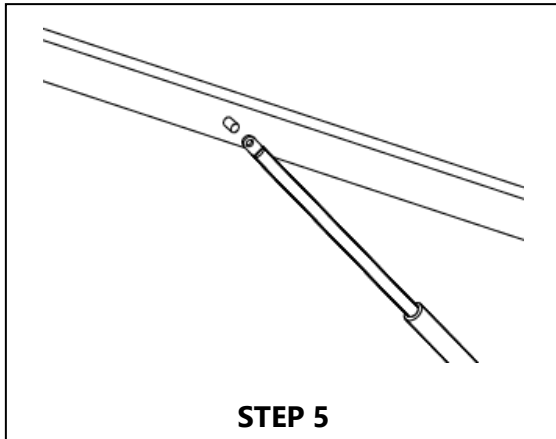

STEP 7 – Repeat Steps 4-6 on the other side rail.

STEP 8 – Identify the head end of your Posture Slat Frame by matching the bolt holes on the side of your Posture Slats with the slots on the Gas Lift Struts (these will be bolted together in the next step). Fix the Mattress Bar to the head end of the Posture Slat Frame as shown below. This will ensure that your mattress will not slide into the bed head when accessing the gas lift storage.

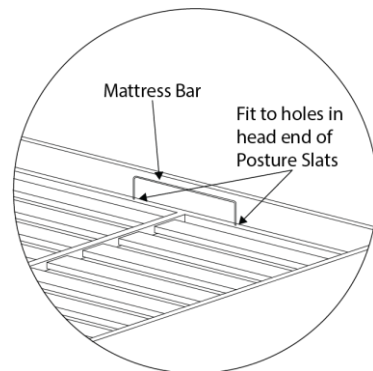
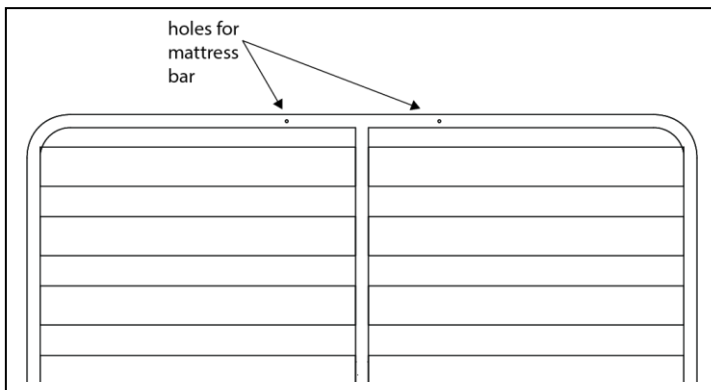

STEP 9 – Place the Posture Slat Frame in position on top of the Gas Lift Struts so that the holes on the Gas Lift Struts line up with the locator holes along the sides of the Posture Slat Frame.

STEP 10 – Slide mushroom head bolts through the holes and use nuts to secure onto the frame. There are slots on the Gas Lift Struts to allow you to adjust the Posture Slat Frame. Use this adjustment so that once the slats are 'closed', it rests on the cleat on the Foot End rail. (Note, without mattress placed on top of Posture Slat Frame, your Gas Lift bed will stay in an 'open' position).

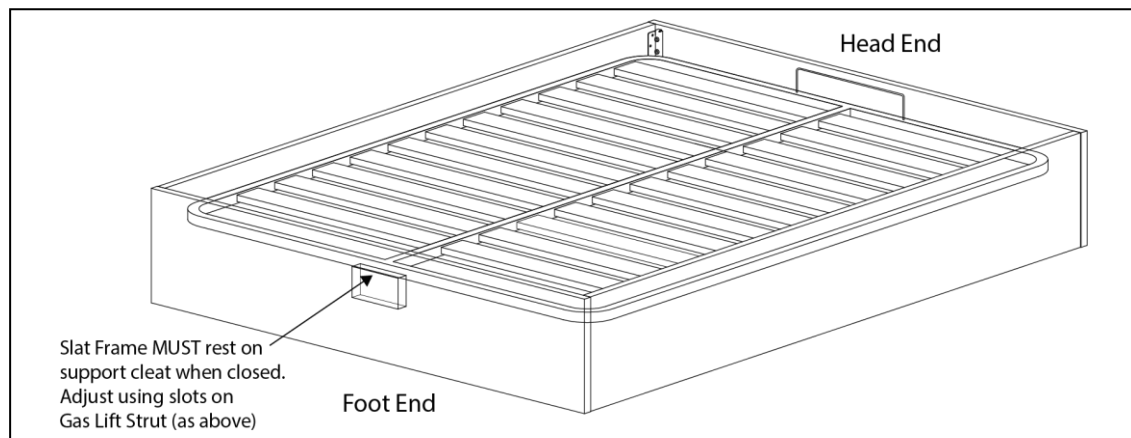
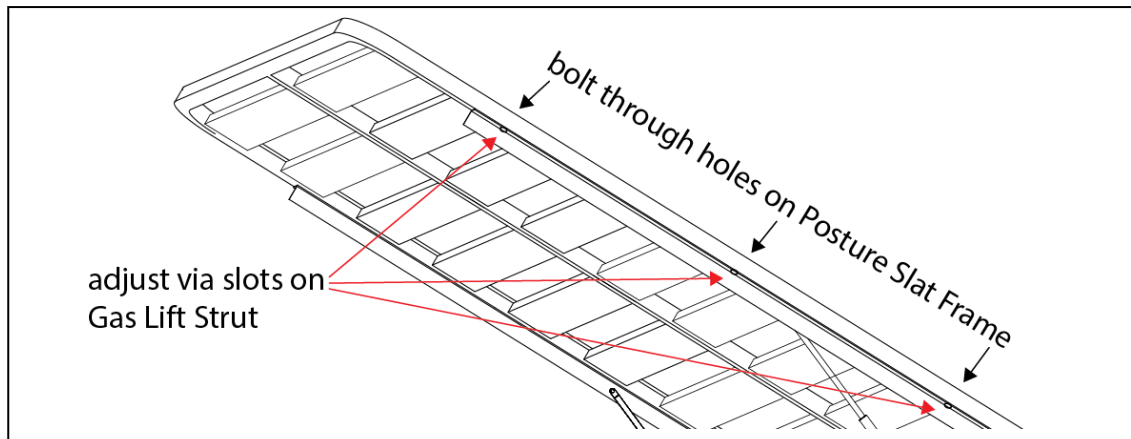

STEP 11 – Fit Support Leg as shown below by fixing to the two locator holes on the under-side of the Posture Slat Frame near the Foot End. Note this step is only necessary if you have either a King Bed (you will install 2 Support Legs) or a Queen Bed (you will install 1 Support Leg). Smaller beds (Double, King Single, and Single do not use a Support Leg).

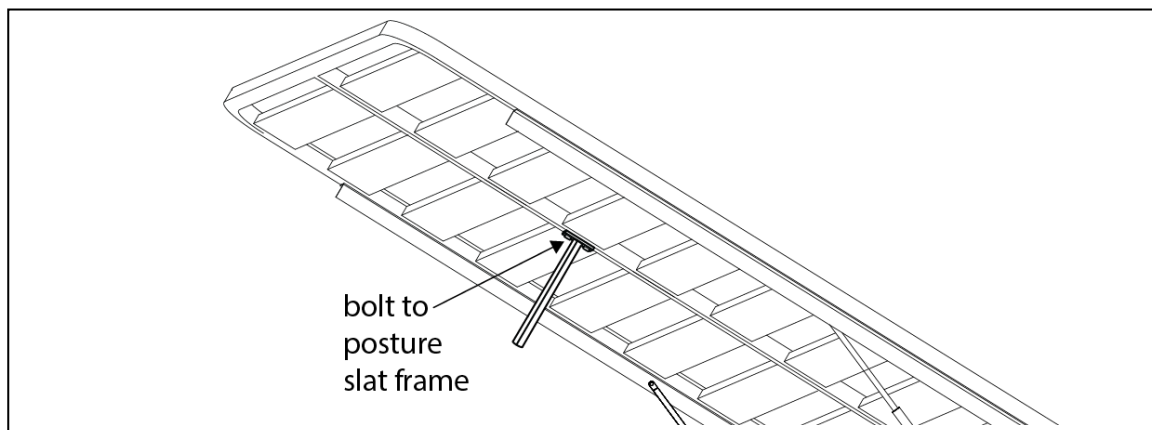

STEP 12 – Fine tune the Support Leg/s by unscrewing the foot so that it sits roughly 5 – 10mm above the floor.

STEP 13 – Loop the Fabric Strap Handle around the foot end of the Posture Slat Frame as shown below. This can now be used as a handle to lift your bed for access to the storage space below.

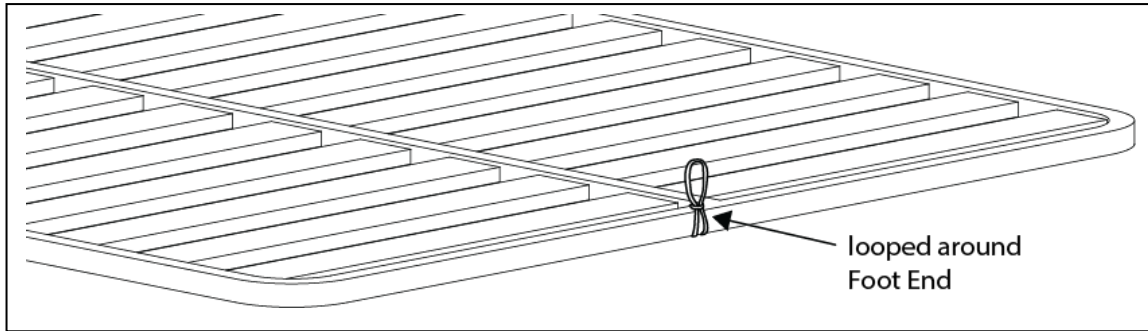

STEP 14 – ‘Close’ the Posture Slat Frame and place your mattress on top. Your Gas Lift Bed is now ready to enjoy!

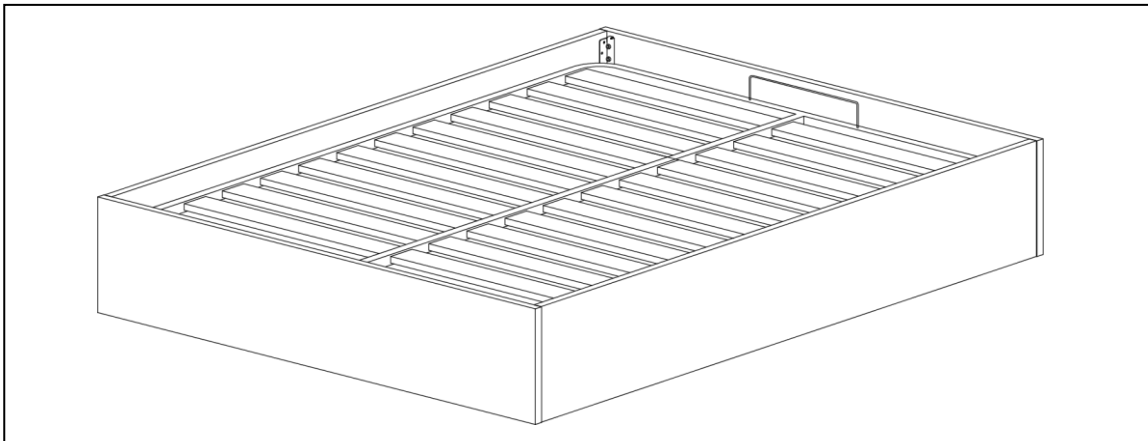

NOTES

- Button head bolts should be regularly inspected and may need to be retightened after a period of time.
- **Never drag or move assembled bed as this may damage the bed**

CARE & MAINTENANCE

Your Silver Lynx product is crafted with care, properly maintained, it will mature over time developing a rich deep patina enhancing its appearance. To get the best performance from your Silver Lynx product, please follow the simple care instructions listed below.

- Do not use silicone based polishes/cleaners at any time.
- Dust surfaces gently with a feather duster then wipe gently with a slightly damp cloth/chamois.
- Do not allow liquids, damp clothes to remain in contact with lacquered surface for extended periods.
- Never place furniture in close proximity to heating outlets.
- Exposure to direct sunlight will cause colour fading to fabrics, leathers and timber finishes.
- Do not allow solvents, abrasives or heated objects to come in contact with the suite.
- Do not use cordless drivers or power drills to tighten your bed brackets, as over-tightening can cause the foot end rail to bow.

Contact your retailer or our sales office for further information